

**PRODUCT
SPECIFICATION**



A TEREX BRAND

5900T

HORIZONTAL GRINDER



WWW.TEREX.COM/CBI

5900T HORIZONTAL GRINDER

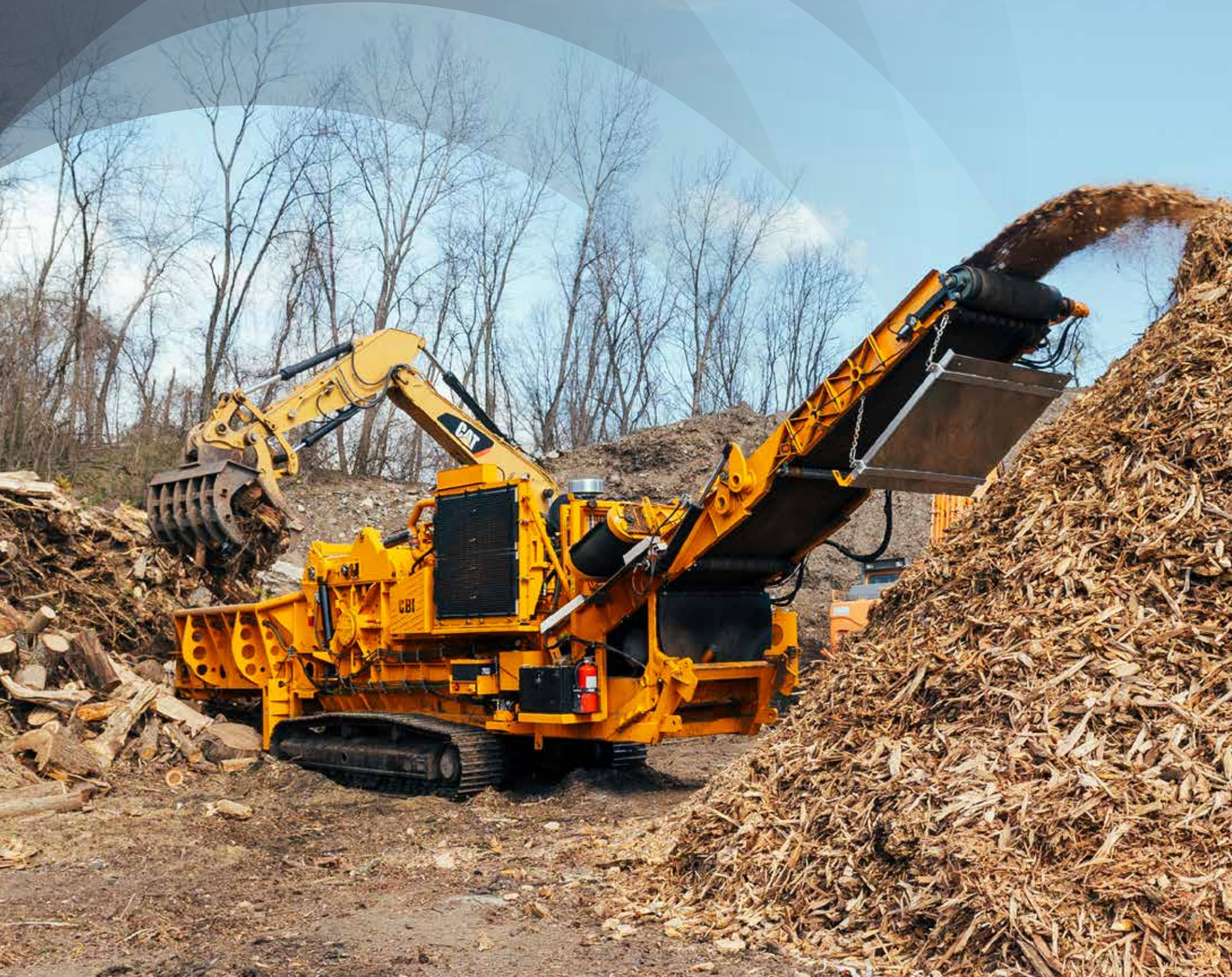

INTRODUCING THE CBI 5900T

A NEW GENERATION OF POWER AND PERFORMANCE.



Designed as the first generation of the 5900, this machine combines the best of both worlds, blending features from the traditional 6800 and the 5800. With its 60" wide infeed rotor, the 5900T significantly enhances material flow, effortlessly handling wider material and reducing the need for pre-processing. Its 8'6" legal transport width and redesigned dolly system enhance mobility and transport efficiency, while

the 755hp engine with hydraulic clutch delivers powerful, smooth performance and precise control. Built for easy maintenance, the 5900T features quick air filter removal and convenient engine access. The updated discharge system, equipped with multiple wear plates and a material-ejecting pulley, boosts durability and performance, making it a machine built for the **toughest challenges.**

5900T HORIZONTAL GRINDER

KEY FEATURES:



THE 5900T FEATURES QUICK AIR FILTER REMOVAL AND CONVENIENT ENGINE ACCESS.

8'6" LEGAL WIDTH AND REDESIGNED DOLLY SYSTEM

BELT HOLD DOWN ROLLERS FOR INCREASED SKIRT RUBBER LIFE



HOG BOX OPENS IN SECONDS ALLOWING QUICK SCREEN CHANGES WITH NO TOOLS REQUIRED

755HP ENGINE WITH HYDRAULIC CLUTCH DELIVERS POWERFUL, SMOOTH PERFORMANCE AND PRECISE CONTROL.

APPLICATIONS



LAND CLEARING



STORM DEBRIS CLEAN UP



M&W



FORESTRY & WOOD PROCESSING



C&D

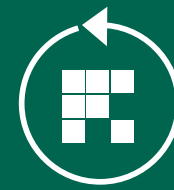

ASPHALT SHINGLE REGRIND



WOOD WASTE RECYCLING



ENHANCED DISCHARGE SYSTEM WITH WEAR PLATES AND OPTIONAL METAL-EJECTING PULLEY—BUILT FOR ULTIMATE DURABILITY AND PERFORMANCE IN TOUGH JOBS.



60" WIDE INFEEED & ROTOR: THE 5900T SIGNIFICANTLY ENHANCES MATERIAL FLOW, EFFORTLESSLY HANDLING WIDER MATERIAL AND REDUCING THE NEED FOR PRE-PROCESSING.

METAL DETECTION SYSTEM (MDS) PROTECTS MACHINE FROM TRAMP METAL

SCREEN HOLDER

5900T HORIZONTAL GRINDER

TECHICAL DATA

TRANSPORT DIMENSIONS		Hydraulics	Hydrostatic: Clutch - HPT015
Width	8'-6" (2,438mm)	Fuel Tank	350 gallons (1591L)
Height	11'-11.3/4" (3,352mm)	INFEED	
Length	40'-10" (12,192mm)	Top Feed Roll	36"D x 57"W
Weight	Base unit 80,000lbs	Width	61' (18,592mm)
WORKING DIMENSIONS		Length	16'-7" (4,876mm)
Length	49'-4" (14,935mm)	GENERAL	
Width	8'-6" (2,438mm)	Controls	Parker IQAN
Feed Height	5'-7" (1,524mm)	Tracks	500mm Triple Grouser
Discharge Height	15'-6" (4,572mm)	Rotor	40"D x 60"W
DISCHARGE CONVEYOR		Options	Air Compressor
Width	48" (1,219mm)		Transport Dolly
Height	15'-6" (4,572mm)		Work Lights
Length	38' (11,582mm)		Scania DC16
POWERTRAIN			CAT C18 T2
Power Unit	Caterpillar, Diesel C18 755-HP (570kW), Tier 4 Final		Segmented Infeed Floor
			Valve Covers
			CE Package
			Magnetic Head Pulley

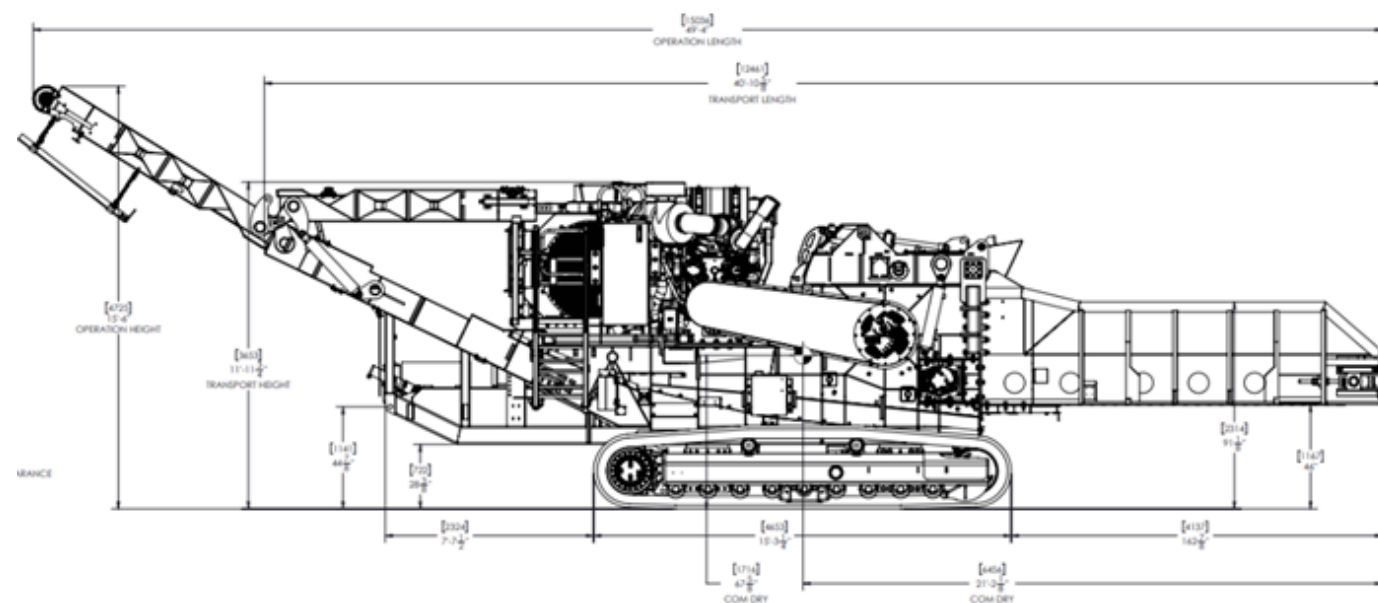

BASE MACHINE WEIGHT DRY 79,500LBS
 MAG HEAD PULLEY: + 400 LBS
 COMPRESSOR: +2875LBS





A TEREX BRAND



The material in this document is for information only and is subject to change without notice.

CBI assumes no liability resulting from errors or omissions in this document, or from the use of the information contained herein. Due to continual product development we reserve the right to change specifications without notice. Product performance figures given in this brochure are for guidance purposes only, this information does not constitute an expressed or implied warranty or guarantee. Results will vary depending on conveyor settings, feed source and types of material being processed.

Images are for illustrative purposes only, some or all of the machines in the illustrations may be fitted with optional extras. Please check with your Dealer for details on optional extras.

CBI is a registered trademark of Terex GB Limited in the United States of America and many other countries.
Copyright 2025 Terex. Published and Printed in 2025. All machines are CE Approved.